

ACU-804

AIR CONDITIONING & HEATING UNITS



The ACU-804 Series is a line of self contained, fully portable air conditioning units suitable for single connection aircraft throughout the world. The ACU-804 has sufficient capacity to achieve and maintain comfortable cabin temperatures on any narrow or medium bodied aircraft in any climate. The simple but rugged design consists of a diesel engine directly driving the refrigeration compressor and blower. This is the unique "TLD Direct Drive" technology. A hydraulically driven condenser fan exhausts waste heat directly upward making it immune to performance fluctuations due to varying wind conditions and minimizing heat and noise radiated to the immediate ramp area.

DESIGN FEATURES

- **Rotary Screw Compressor** - variable capacity rotary screw continuously adjusts its capacity to accommodate the demand. This component is designed to operate for 50,000 hours before requiring major service.
- **Emission Certified Engines** - choice of Deutz or Cummins diesel engines. Heavy-duty industrial engines rated for continuous duty provide ample power in all operating conditions. Engines are selected to meet current and future U.S. EPA and European COM emission standards.
- **Automatic Capacity Control** monitors unit output and cooling demand and adjusts capacity to provide efficient operation.
- **Simplified Operating Controls** provide an operator interface common to other TLD equipment.
- **Adjustable Outlet Damper** for single-handed control of outlet flow & pressure.
- **High Capacity Centrifugal Blower** supplies abundant airflow and delivery pressure to accommodate modern aircraft.
- **24 Volt Electrical System** for trouble-free control operation and commonality with other industrial equipment.
- **Heavy-duty steel fuel tank** is sized for at least eight hours of continuous operation under any operating conditions.
- **Industry proven R134a** refrigerant is recognized as having Zero Ozone Depletion Potential and is considered environmentally acceptable in all regions. Because R134a inherently operates at a lower pressure for a given temperature, an R134a system maintains its operating efficiency in extremely hot ambient conditions.

ACU-804

AIR CONDITIONING & HEATING UNITS



OPTIONAL EQUIPMENT

- Fuel filter / water separator with heater
- Low fuel warning system with flashing or rotating beacon, red or amber lens
- Low fuel warning and shutdown system with flashing or rotating beacon, red or amber lens
- Warning beacon, flashing or rotating, red or amber
- Engine block heater, 120 or 240 VAC
- Engine warm up timer
- Engine cool down timer

DESIGN SPECIFICATIONS

Cooling Capacity	Nominal Tons Refrigeration	65
Air Flow	lb/min (kg/min)	to 375 (170)
Supplied Air Temperature (@100°F & 55% RH)	°F (°C)	35-50 (2-10)
Compressor Manufacturer		Frick
Compressor Model		XJS-120S
Compressor Type		Rotary Screw
Capacity Control		Automatic, Pressure Controlled
Heating Capacity	btu/hr (kW)	350,000 (103)
Heating Ambient	°F (°C)	Below 0 (Below -18)
Heating Air Temperature	°F (°C)	90-130 (38-54)

AVAILABLE CONFIGURATION

Engine	Deutz TCD2012L062V	Cummins QSB6.7	
Tier Level	Tier 3/ Com IIIA	Tier 3/ Com IIIA	Tier 4/ Com IV
Mounting	Trailer with 5th wheel		
Weight	Lbs (kg)	9,700 (4,410)	10,420 (4726)

DIMENSIONS (Approximate)

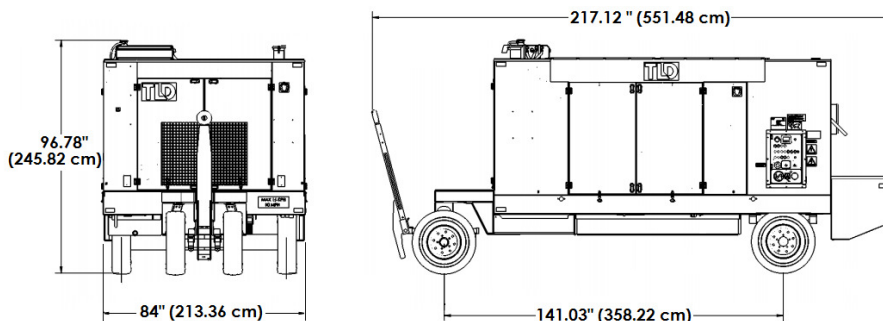

LOCAL SUPPORT, TOTAL COMMITMENT

Revised on 11/04/15 SJK

TLD Sales and Service regional headquarters

- **TLD ASIA** South East Asia & South Korea
Hong Kong Tel : + 852 2 692-2181
- **TLD CHINA** China
Shanghai, PRC Tel : + 86 21 5815 3322
- **TLD EUROPE** Europe, Russia, Central Asia, & West Africa
Montlouis-sur-Loire, France Tel : + 33 2 47 45 77 77
- **TLD MEAI** Middle East, East Africa & India
Dubai, UAE Tel : + 971 47 030 410
- **TLD LAAJ** Latin America, Oceania & Japan
Miami, FL, USA Tel : + 1 (305) 716 1130
- **TLD AMERICA** USA & Canada
Windsor, CT, USA Tel : + 1 (860) 602-3400

ACU-804 datasheet_C

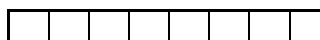
Contact us on our Web Site: www.TLD-group.com

Tolerances of mentioned data: +/- 5 %
Specifications may be altered due to a constant effort to improve performance.